

# SILVERADO & SILVERADO HD REGULAR CAB BUYER'S GUIDE

S = Standard O = Optional - = Not Available

## EXTERIOR

	WT	1LT
1LT Convenience Package: includes remote vehicle starter system, steering wheel-mounted controls and foglamps	-	O
Cargo Management System: configurable, sliding hook system in pickup bed	O	O
EZ Lift Tailgate Package: includes lockable EZ Lift tailgate	-	O
Fog lamps: halogen	-	O <sup>1</sup>
LS Package: includes 17-inch chrome styled-steel wheels, chrome-surround grille and front bumper, body-color front bumper end caps and LS badging (1500 models)	O	-
Mirrors: - Black, foldaway outside	S	-
- Black, foldaway, power, heated outside	-	S
- trailering, high-visibility vertical, manual foldaway and extendable, Black with lower convex spotter glass	O	-
- trailering, vertical, power, heated, manual foldaway and extendable, Black with turn-signal indicators and lower convex spotter glass	-	O
Recovery hooks: two front	O <sup>2</sup>	S

## ENGINE/CHASSIS

	WT	1LT
Air cleaner: high-capacity (1500 models; standard in HD models)	O	O
Batteries: - heavy-duty, 600 cold-cranking amps	S	S
- auxiliary, heavy-duty, 600 cold-cranking amps (HD models; requires Vortec 6.0L V8)	O	O
- heavy-duty, 730 cold-cranking amps (HD models; requires Duramax Diesel 6.6L V8)	O	O
Differential: automatic locking rear	O	O
Engine block heater	O	O
Fuel capacities (approximate): - Standard Box models (26-gallon)	S	S
- Long Box models (34-gallon)	S	S
Oil coolers: - engine, heavy-duty, external (HD models)	S	S
- transmission, auxiliary, heavy-duty, external (HD models)	S	S
Skid Plate Package: <sup>3</sup> includes frame-mounted shield protecting front underbody, oil pan, differential case and transfer case (on 4x4 models)	O	O
Suspensions: - Z83 Solid Smooth Ride (1500 models)	S	S
- Z85 Handling/Trailering (1500 models; standard on HD models)	O	O
- Z71 Off-Road (1500 and HD SRW models)	-	O

## ENGINE/CHASSIS (CONTINUED)

	WT	1LT
Towing Package: includes high-capacity air cleaner, auxiliary external transmission oil cooler, automatic locking rear differential and heavy-duty trailering equipment (1500 models)	O <sup>4</sup>	-
Trailering equipment: heavy-duty, includes trailer hitch platform, seven-wire harness mated to seven-way sealed connector, trailer brake control jumper harness, high-capacity air cleaner, sealed connector for center high-mounted brake lamp and external transmission oil cooler	O <sup>5</sup>	O
Transfer cases (4x4 models only): - floor-mounted, manual shift-on-the-fly	S	-
- Autotrac, active (1500 models)	-	S
- electronic with rotary dial (HD models)	-	S
Z71 Off-Road Package: includes Skid Plate Package; off-road jounce bumpers, shock absorbers and stabilizer bars; high-capacity air cleaner in 1500 models; Z71 decals; and automatic locking rear differential (1500 and HD SRW models)	-	O

## SEATING

	WT	1LT
Vinyl 40/20/40 split-bench front seats with recliners (also available in cloth)	S	-
Select Cloth 40/20/40 split-bench front seats with recliners, fold-down center armrest with storage, and lockable underseat storage (also available with Custom Leather-appointed trim)	-	S

## INTERIOR

	WT	1LT
Climate (temperature) control: single-zone, manual	O	S
Cruise control	O	S
Defogger: rear-window	O	S
Door locks: power, programmable	O	S
Driver Information Center	S	S
Glove boxes: dual	S	S
Mirror, inside rearview: auto-dimming with eight-point compass and outside temperature display	-	S
Remote vehicle starter system	-	O <sup>1</sup>
Steering column: Tilt-Wheel, adjustable	S	S
Steering wheel-mounted controls: audio system	-	O <sup>1</sup>
Windows: power with driver's Express-Down feature	-	S

## SAFETY AND SECURITY

	WT	1LT
Air bags: <sup>6</sup> - driver and right-front passenger (HD models)	S	S
- driver and right-front passenger with Passenger Sensing System (1500 models)	S	S
- front and rear head-curtain side-impact (1500 models)	-	O
Brake controller: trailer, ABS-integrated	O	O
Brakes: four-wheel antilock brake system (ABS) with Dynamic Rear Proportioning	S	S
OnStar: <sup>7</sup> with one-year Safe & Sound Plan	S	S
Remote Keyless Entry: includes content-theft alarm and two transmitters	O	S

## AUDIO SYSTEMS

	WT	1LT
AM/FM stereo with MP3-compatible CD player	S	S
AM/FM stereo with MP3-compatible in-dash six-disc CD changer	-	O
XM Radio: <sup>8</sup> includes three trial months of service	S	S

PICKUP MODEL	SERIES	DRIVE	TRIM LEVELS	STANDARD ENGINE	HP @ RPM	TORQUE @ RPM	STANDARD TRANSMISSIONS	OPTIONAL ENGINES	GVWR <sup>9</sup> (LBS.)	MAX. PAYLOAD <sup>10</sup> (LBS.)
REGULAR CAB STANDARD BOX	1500 (1/2-ton)	2WD/4x4	Work Truck	Vortec 4.3L V6	195 @ 4,600	260 @ 2,800	Hydra-Matic 4-speed automatic overdrive	Vortec 4.8L V8, Vortec 5.3L V8	6,400	1,947 (2WD) 1,722 (4x4)
			1LT	Vortec 4.8L V8	295 @ 5,600	305 @ 4,800	Hydra-Matic 4-speed automatic overdrive	Vortec 5.3L V8	6,400	1,831 (2WD) 1,596 (4x4)
REGULAR CAB LONG BOX	1500 (1/2-ton)	2WD/4x4	Work Truck	Vortec 4.3L V6	195 @ 4,600	260 @ 2,800	Hydra-Matic 4-speed automatic overdrive	Vortec 4.8L V8, Vortec 5.3L V8	6,400	1,806 (2WD) 1,575 (4x4)
			1LT	Vortec 4.8L V8	295 @ 5,600	305 @ 4,800	Hydra-Matic 4-speed automatic overdrive	Vortec 5.3L V8	6,400 (2WD) 6,800 (4x4)	1,701 (2WD) 1,854 (4x4)
	2500HD (3/4-ton)	2WD/4x4	Work Truck, 1LT	Vortec 6.0L V8	353 @ 5,400	373 @ 4,400	Hydra-Matic 6-speed automatic overdrive	Duramax Diesel 6.6L V8 Turbo	9,200	3,892 (2WD) 3,646 (4x4)
	3500HD (1-ton)	2WD/4x4	Work Truck, 1LT	Vortec 6.0L V8	353 @ 5,400 <sup>11</sup> 312 @ 4,400 <sup>12</sup>	373 @ 4,400	Hydra-Matic 6-speed automatic overdrive	Duramax Diesel 6.6L V8 Turbo <sup>13</sup>	9,700 <sup>11</sup> (2WD) 9,900 <sup>11</sup> (4x4) 11,400 <sup>12</sup> (4x4)	4,608 <sup>11</sup> (2WD) 3,654 <sup>11</sup> (4x4) 5,307 <sup>12</sup> (4x4)

<sup>1</sup> Requires the available 1LT Convenience Package. <sup>2</sup> Standard on all 1500 4x4 and HD models. <sup>3</sup> Included with Z71 Off-Road Package and Snow Plow Prep Package. 2WD models require Z71 Off-Road Package. <sup>4</sup> Includes Z85 Handling/Trailering suspension. <sup>5</sup> Not available with Vortec 4.3L V6 engine or Z83 Solid Smooth Ride suspension. <sup>6</sup> Always use safety belts and the correct child restraint for your child's age and size. Even in vehicles equipped with the Passenger Sensing System, children are safer when properly secured in a rear seat in the appropriate infant, child or booster seat. Never place a rear-facing infant restraint in the front seat of any vehicle equipped with an active air bag. See the vehicle Owner's Manual and child safety seat instructions for more information. <sup>7</sup> Call 1-888-4ONSTAR (1-888-466-7827), visit onstar.com and see page 47 for system limitations and details. OnStar acts as a link to emergency services. <sup>8</sup> Available only in the 48 contiguous United States. Required \$12.95 monthly subscription sold separately after three trial months. All fees and programming subject to change. Subscription subject to customer agreement. For more information, visit gm.xmradio.com. <sup>9</sup> Gross Vehicle Weight Rating (GVWR). When properly equipped; includes vehicle, passengers, cargo and equipment. <sup>10</sup> Maximum payload capacity includes weight of driver, passengers, optional equipment and cargo. Cargo and load capacity limited by weight and distribution. <sup>11</sup> Single-Rear Wheel. <sup>12</sup> Dual-Rear Wheel. <sup>13</sup> Not available on 2WD models.

# SILVERADO & SILVERADO HD EXTENDED CAB BUYER'S GUIDE

S = Standard O = Optional - = Not Available

## EXTERIOR

	WT	1LT	2LT	LTZ
1LT Convenience Package: includes remote vehicle starter system, steering wheel-mounted controls, dual-zone automatic temperature controls and foglamps	-	O	-	-
2LT Convenience Package: includes remote vehicle starter system; Universal Home Remote transmitter; power, heated outside mirrors with turn-signal indicators in glass, driver-side auto-dimming feature, power-foldaway feature and curb-tilt; and heated windshield washer fluid system	-	-	O	-
Cargo Management System: configurable, sliding hook system in pickup bed	O	O	O	O
EZ Lift Tailgate Package: includes lockable EZ Lift tailgate	-	O	O	O
Foglamps: halogen	-	O <sup>1</sup>	S	S
LS Package: includes 17-inch chrome styled-steel wheels, chrome-surround grille and front bumper, and body-color front bumper end caps (1500 models)	O	-	-	-
Mirrors: — Black, foldaway outside — Black, foldaway, power, heated outside — Power, heated outside with turn-signal indicators in glass, driver-side auto-dimming feature, power-foldaway feature and curb-tilt — trailing, high-visibility vertical, manual foldaway and extendable, Black with lower convex spotter glass — trailing, vertical, power, heated, manual foldaway and extendable, Black with turn-signal indicators and lower convex spotter glass	S - - O	- S - -	- S O <sup>2,3</sup> -	- - S <sup>4</sup> -
Recovery hooks: two front	O <sup>5</sup>	S	S	S
Ultrasonic Rear Parking Assist <sup>6</sup>	-	O	O	O
Windshield washer fluid system: heated	-	-	O <sup>3</sup>	S

## ENGINE/CHASSIS

Air cleaner: high-capacity (1500 models; standard in HD models)	O	O	O	S
Batteries: — heavy-duty, 600 cold-cranking amps — auxiliary, heavy-duty, 600 cold-cranking amps (HD models; requires Vortec 6.0L V8) — heavy-duty, 730 cold-cranking amps (HD models; requires Duramax Diesel 6.6L V8)	S O O	S O O	S O O	S O O
Differential: automatic locking rear	O	O	O	S
Engine block heater	O	O	O	O
Fuel capacities (approximate): — Short and Standard Box models (26-gallon) — Long Box models (34-gallon)	S S	S S	S S	S S
MAX Trailing Pack: <sup>7</sup> includes automatic locking rear differential, 9.5-inch rear axle, front and rear disc brakes, Z85 Handling/Trailer suspension, and heavy-duty trailering equipment (1500 Standard Box models only)	-	O	O	O
Power Pack Plus: includes Vortec 5.3L V8 engine, automatic locking rear differential, heavy-duty trailering equipment and 16-in. custom aluminum wheels	-	O	-	-
Oil coolers: — transmission, auxiliary, heavy-duty, external (1500 models; standard in HD models) — engine, heavy-duty, external (requires Vortec Max 6.0L V8 in 1500 models; standard in HD models)	O -	O O	O O	S O

## ENGINE/CHASSIS (CONTINUED)

	WT	1LT	2LT	LTZ
Skid Plate Package: <sup>8</sup> includes frame-mounted shield protecting front underbody, oil pan, differential case and transfer case (on 4x4 models)	O	O	O	O
Suspensions: — Z83 Solid Smooth Ride (1500 models) — Z85 Handling/Trailer (1500 models; standard on HD models) — Z60 High-Performance <sup>9</sup> (1500 models) — Z71 Off-Road (1500 and HD SRW models)	S O - -	- S O O	- S O O	- S O O
Towing Package: includes high-capacity air cleaner, auxiliary external transmission oil cooler, automatic locking rear differential and heavy-duty trailering equipment (1500 models)	O <sup>10</sup>	-	O	O
Trailer equipment: heavy-duty, includes trailer hitch platform, seven-wire harness mated to seven-way sealed connector, trailer brake control jumper harness, high-capacity air cleaner, sealed connector for center high-mounted brake lamp and external transmission oil cooler	O <sup>11</sup>	O	O	S
Transfer cases (4x4 models only): — floor-mounted, manual shift-on-the-fly — Autotrac, active (1500 models) — electronic with rotary dial (HD models)	S - -	- S S	- S S	- S S
Z71 Off-Road Package: includes Skid Plate Package; off-road jounce bumpers, shock absorbers and stabilizer bars; high-capacity air cleaner in 1500 models; Z71 decals; and automatic locking rear differential (1500 and HD SRW models)	-	O	O	O

## SEATING

Vinyl 40/20/40 split-bench seats with recliners (also available in cloth)	S	-	-	-
Select Cloth 40/20/40 split-bench front seats with recliners, fold-down center armrest with storage, and lockable underseat storage (also available with Custom Leather-appointed trim)	-	S	-	-
Premium Cloth reclining, six-way power-adjustable front bucket seats (also available with Custom Leather-appointed trim)	-	-	S	-
Custom Leather-appointed, reclining, heated, 10-way power-adjustable front bucket seats	-	-	-	S
Rear seats: — flip-up, full-width bench — flip-up, 60/40 split-bench	S -	- S	- S	- S

## INTERIOR

Climate (temperature) control: single-zone, manual	S	S	-	-
Climate (temperature) controls: dual-zone, automatic	-	O <sup>1</sup>	S	S
Cruise control	O	S	S	S
Fogger: rear-window (not available with power-sliding rear window)	O	S	S	S
Door locks: power, programmable	O	S	S	S
Driver Information Center	S	S	S	S
Glove boxes: dual	S	S	S	-
Mirror, inside rearview: auto-dimming with eight-point compass and outside temperature display	-	S	S	S
Remote vehicle starter system	-	O <sup>1</sup>	O <sup>3</sup>	S

## INTERIOR (CONTINUED)

	WT	1LT	2LT	LTZ
Steering column: Tilt-Wheel, adjustable	S	S	S	S
Steering wheel-mounted controls: audio system	-	O <sup>1</sup>	S	S
Sunroof: power-sliding with Express-Open and wind deflector	-	O <sup>1</sup>	O	O
Window: power-sliding, rear	-	O	O	O
Windows: power, full-drop with driver's Express-Down feature	-	S	S	S

## SAFETY AND SECURITY

Air bags: <sup>12</sup> — driver and right-front passenger with Passenger Sensing System — front and rear head-curtain side-impact	S -	S O	S O	S O
Brake controller: trailer, ABS-integrated	O	O	O	O
Brakes: four-wheel antilock brake system (ABS) with Dynamic Rear Proportioning	S	S	S	S
OnStar: <sup>13</sup> with one-year Safe & Sound Plan	S	S	S	S

## SAFETY AND SECURITY (CONTINUED)

	WT	1LT	2LT	LTZ
Remote Keyless Entry: includes content-theft alarm and two transmitters	O	S	S	S
Safety Package: includes power-adjustable pedals, head-curtain side-impact air bags and Ultrasonic Rear Parking Assist	-	O	O	O
StabiliTrak Electronic Stability Control System (1500 Standard Box models)	-	O	O	O

## AUDIO SYSTEMS

AM/FM stereo with MP3-compatible CD player	S	S	S	S
AM/FM stereo with MP3-compatible in-dash six-disc CD changer	-	O	O	O
Bose <sup>®</sup> speaker system	-	-	O	S
Touch-screen navigation radio <sup>14</sup>	-	-	-	O
XM Radio: <sup>15</sup> includes three trial months of service	S	S	S	S

PICKUP MODEL	SERIES	DRIVE	TRIM LEVELS	STANDARD ENGINE	HP @ RPM	TORQUE @ RPM	STANDARD TRANSMISSIONS	OPTIONAL ENGINES	GVWR <sup>16</sup> (LBS.)	MAX. PAYLOAD <sup>17</sup> (LBS.)
EXTENDED CAB SHORT BOX	1500 (1/2-ton)	2WD	Work Truck, 1LT, 2LT, LTZ	Vortec 4.3L V8 <sup>18</sup>	195 @ 4,600	260 @ 2,800	Hydra-Matic 4-speed automatic overdrive	Vortec 4.8L V8, Vortec 5.3L V8, Vortec MAX 6.0L V8	6,400	1,530
		4x4	Work Truck, 1LT, 2LT, LTZ	Vortec 4.8L V8 <sup>18</sup>	295 @ 5,600	305 @ 4,800	Hydra-Matic 4-speed automatic overdrive	Vortec 5.3L V8, Vortec MAX 6.0L V8	6,800	1,574
EXTENDED CAB STANDARD BOX	1500 (1/2-ton)	2WD	Work Truck	Vortec 4.3L V6	195 @ 4,600	260 @ 2,800	Hydra-Matic 4-speed automatic overdrive	Vortec 4.8L V8, Vortec 5.3L V8	6,400	1,477
		4x4	Work Truck	Vortec 4.8L V8	295 @ 5,600	305 @ 4,800	Hydra-Matic 4-speed automatic overdrive	Vortec 5.3L V8	7,000	1,754
MAX Trailing Pack	2500HD (3/4-ton)	2WD/4x4	1LT	Vortec 4.8L V8	295 @ 5,600	305 @ 4,800	Hydra-Matic 4-speed automatic overdrive	Vortec 5.3L V8, Vortec MAX 6.0L V8	6,800 (2WD) 7,000 (4x4)	1,773 (2WD) 1,754 (4x4)
		2WD/4x4	2LT, LTZ	Vortec 5.3L V8	315 @ 5,200	338 @ 4,400	Hydra-Matic 4-speed automatic overdrive	Vortec MAX 6.0L V8	6,800 (2WD) 7,000 (4x4)	1,760 (2WD) 1,734 (4x4)
EXTENDED CAB LONG BOX	1500 (1/2-ton)	2WD/4x4	Work Truck, 1LT, 2LT, LTZ	Vortec 5.3L V8	315 @ 5,200	338 @ 4,400	Hydra-Matic 4-speed automatic overdrive	-	6,900 (2WD) 7,000 (4x4)	1,736 (2WD) 1,638 (4x4)
		2500HD (3/4-ton)	Work Truck, 1LT, 2LT, LTZ	Vortec 6.0L V8	353 @ 5,400	373 @ 4,400	Hydra-Matic 6-speed automatic overdrive	Duramax Diesel 6.6L V8	9,200	3,465 (2WD) 3,194 (4x4)
	3500HD (1-ton)	2WD/4x4	Work Truck, 1LT, 2LT, LTZ	Vortec 6.0L V8	353 @ 5,400 <sup>19</sup> 312 @ 4,400 <sup>20</sup>	373 @ 4,400	Hydra-Matic 6-speed automatic overdrive	Duramax Diesel 6.6L V8	9,900 <sup>19</sup> 11,400 <sup>20</sup>	4,128 <sup>19</sup> /5,127 <sup>20</sup> (2WD) 3,880 <sup>19</sup> /4,863 <sup>20</sup> (4x4)

<sup>1</sup> Requires the available 1LT Convenience Package. <sup>2</sup> Mirrors are Black. <sup>3</sup> Requires the available 2LT Convenience Package. <sup>4</sup> Mirror caps are body-color. <sup>5</sup> Standard on 1500 4x4 models and all HD models. <sup>6</sup> Requires the available Safety Package. <sup>7</sup> Requires the available Vortec MAX 6.0L V8 engine and StabiliTrak Electronic Stability Control System. <sup>8</sup> Included with Z71 Off-Road Package and Snow Plow Prep Package. 2WD models require Z71 Off-Road Package. <sup>9</sup> Not available on Long Box models or on trucks equipped with Vortec 4.3L V6 or 4.8L V8 engines. Requires available 20-inch five-spoke machined-aluminum wheels. <sup>10</sup> Includes Z85 Handling/Trailer suspension. <sup>11</sup> Not available with Vortec 4.3L V6 engine or Solid Smooth Ride suspension. <sup>12</sup> Always use safety belts and the correct child restraint for your child's age and size. Even in vehicles equipped with the Passenger Sensing System, children are safer when properly secured in a rear seat in the appropriate infant, child or booster seat. Never place a rear-facing infant restraint in the front seat of any vehicle equipped with an active air bag. See the vehicle Owner's Manual and child safety seat instructions for more information. <sup>13</sup> Call 1-888-4ONSTAR (1-888-466-7827), visit onstar.com and see page 47 for system limitations and details. OnStar acts as a link to emergency services. <sup>14</sup> Map coverage not available in Puerto Rico, the Virgin Islands and portions of Canada. <sup>15</sup> Available only in the 48 contiguous United States. Required \$12.95 monthly subscription sold separately after three trial months. All fees and programming subject to change. Subscription subject to customer agreement. For more information, visit gm.xmradio.com. <sup>16</sup> Gross Vehicle Weight Rating (GVWR). When properly equipped; includes vehicle, passengers, cargo and equipment. <sup>17</sup> Maximum payload capacity includes weight of driver, passengers, optional equipment and cargo. Cargo and load capacity limited by weight and distribution. <sup>18</sup> Standard engine depends on trim level. <sup>19</sup> Single-Rear Wheel. <sup>20</sup> Dual-Rear Wheel.

# SILVERADO & SILVERADO HD CREW CAB BUYER'S GUIDE

S = Standard O = Optional - = Not Available

EXTERIOR	WT	LS <sup>1</sup>	1LT	2LT	L TZ	
1LT Convenience Package: includes remote vehicle starter system, steering wheel-mounted controls, dual-zone automatic temperature controls and foglamps	-	-	0	-	-	
2LT Convenience Package: includes remote vehicle starter system; Universal Home Remote transmitter; power, heated outside mirrors with turn-signal indicators in glass, driver-side auto-dimming feature, power-foldaway feature and curb-tilt; and heated windshield washer fluid system	-	-	-	0	-	
Cargo Management System: configurable, sliding hook system in pickup bed	0	0	0	0	0	
EZ Lift Tailgate Package: includes lockable EZ Lift tailgate	-	-	0	0	0	
Fog lamps: halogen	-	-	0 <sup>2</sup>	S	S	
Mirrors: — Black, foldaway outside — Black, foldaway, power, heated outside — Power, heated outside with turn-signal indicators in glass, driver-side auto-dimming feature, power-foldaway feature and curb-tilt — trailing, high-visibility vertical, manual foldaway and extendable, Black with lower convex spotter glass — trailing, vertical, power, heated, manual foldaway and extendable, Black with turn-signal indicators and lower convex spotter glass	S - - 0	- S - -	- S - -	- S - -	- - 0 <sup>3,4</sup> -	- - S <sup>5</sup> -
Recovery hooks: two front	0 <sup>6</sup>	0 <sup>6</sup>	S	S	S	
Ultrasonic Rear Parking Assist <sup>7</sup>	-	-	0	0	0	
Windshield washer fluid system: heated	-	-	-	0 <sup>4</sup>	S	
Wipers: flat, intermittent with Rainsense	-	-	-	-	0	
<b>ENGINE/CHASSIS</b>						
Air cleaner: high-capacity (1500 models; standard in HD models)	0	0 <sup>8</sup>	0	0	S	
Batteries: — heavy-duty, 600 cold-cranking amps — auxiliary, heavy-duty, 600 cold-cranking amps (HD models; requires Vortec 6.0L V8) — heavy-duty, 730 cold-cranking amps (HD models; requires Duramax Diesel 6.6L V8)	S 0 0	S 0 0	S 0 0	S 0 0	S 0 0	
Differential: automatic locking rear	0	0	0	0	S	
Engine block heater	0	0	0	0	0	
Fuel capacities (approximate): — Short and Standard Box models (26-gallon) — Long Box models (34-gallon)	S S	S -	S S	S S	S S	
MAX Trailing Pack: <sup>9</sup> includes automatic locking rear differential, 9.5-inch rear axle, front and rear disc brakes, Z85 Handling/Trailer suspension, and heavy-duty trailering equipment (1500 Standard Box models only)	-	-	0	0	0	
Power Pack Plus: includes Vortec 5.3L V8 engine, automatic locking rear differential, heavy-duty trailering equipment and 16-in. custom aluminum wheels	-	-	0	-	-	

ENGINE/CHASSIS (CONTINUED)	WT	LS <sup>1</sup>	1LT	2LT	L TZ
Oil coolers: — transmission, auxiliary, heavy-duty, external (1500 models; standard in HD models) — engine, heavy-duty, external (requires Vortec Max 6.0L V8 in 1500 models; standard in HD models)	0 -	0 <sup>8</sup> -	0 0	0 0	S 0
Skid Plate Package: <sup>10</sup> includes frame-mounted shield protecting front underbody, oil pan, differential case and transfer case (on 4x4 models)	0	0	0	0	0
Suspensions: — Z83 Solid Smooth Ride (1500 models) — Z85 Handling/Trailer (1500 models; standard on HD models) — Z60 High-Performance <sup>11</sup> (1500 models) — Z71 Off-Road (1500 and HD SRW models)	S 0 - -	S 0 <sup>8</sup> - -	- S 0 0	- S 0 0	- S 0 0
Towing Package: includes high-capacity air cleaner, auxiliary external transmission oil cooler, automatic locking rear differential and heavy-duty trailering equipment (1500 models)	0 <sup>12</sup>	0 <sup>12</sup>	-	0	0
Trailer equipment: heavy-duty, includes trailer hitch platform, seven-wire harness mated to seven-way sealed connector, trailer brake control jumper harness, high-capacity air cleaner, sealed connector for center high-mounted brake lamp and external transmission oil cooler	0 <sup>13</sup>	0 <sup>8</sup>	0	0	S
Transfer cases (4x4 models only): — floor-mounted, manual shift-on-the-fly — Autotrac, active (1500 models) — electronic with rotary dial (HD models)	S - -	S - -	- S S	- S S	- S S
Z71 Off-Road Package: includes Skid Plate Package; off-road jounce bumpers, shock absorbers and stabilizer bars; high-capacity air cleaner in 1500 models; Z71 decals; and automatic locking rear differential (1500 and HD SRW models)	-	-	0	0	0
<b>SEATING</b>					
Vinyl 40/20/40 split-bench seats with recliners	S	-	-	-	-
Cloth 40/20/40 split-bench seats with recliners	0	S	-	-	-
Select Cloth 40/20/40 split-bench front seats with recliners, fold-down center armrest with storage, and lockable underseat storage (also available with Custom Leather-appointed trim)	-	-	S	-	-
Premium Cloth reclining, six-way power-adjustable front bucket seats (also available with Custom Leather-appointed trim)	-	-	-	S	-
Custom Leather-appointed, reclining, heated, 10-way power-adjustable front bucket seats	-	-	-	-	S
Rear seats: flip-up, 60/40 split-bench	S	S	S	S	S
<b>INTERIOR</b>					
Climate (temperature) control: single-zone, manual	S	S	S	-	-
Climate (temperature) controls: dual-zone, automatic	-	-	0 <sup>2</sup>	S	S
Cruise control	0	S	S	S	S

INTERIOR (CONTINUED)	WT	LS <sup>1</sup>	1LT	2LT	L TZ
Defogger: rear-window (not available with power-sliding rear window)	0	S	S	S	S
Door locks: power, programmable	S	S	S	S	S
Driver Information Center	S	S	S	S	S
Glove boxes: dual	S	S	S	S	-
Mirror, inside rearview: auto-dimming with eight-point compass and outside temperature display	-	-	S	S	S
Remote vehicle starter system	-	-	0 <sup>2</sup>	0 <sup>4</sup>	S
Steering column: Tilt-Wheel, adjustable	S	S	S	S	S
Steering wheel-mounted controls: audio system	-	-	0 <sup>2</sup>	S	S
Sunroof: power-sliding with Express-Open and wind deflector	-	-	0 <sup>2</sup>	0	0
Window: power-sliding, rear	-	-	0	0	0
Windows: power, full-drop with driver's Express-Down feature	-	S	S	S	S
<b>SAFETY AND SECURITY</b>					
Air bags: <sup>14</sup> — driver and right-front passenger with Passenger Sensing System — front and rear head-curtain side-impact	S -	S -	S 0	S 0	S 0

SAFETY AND SECURITY (CONTINUED)	WT	LS <sup>1</sup>	1LT	2LT	L TZ
Brake controller: trailer, ABS-integrated	0	0	0	0	0
Brakes: four-wheel antilock brake system (ABS) with Dynamic Rear Proportioning	S	S	S	S	S
OnStar: <sup>15</sup> with one-year Safe & Sound Plan	S	S	S	S	S
Remote Keyless Entry: includes content-theft alarm and two transmitters	0	S	S	S	S
Safety Package: includes power-adjustable pedals, head-curtain side-impact air bags and Ultrasonic Rear Parking Assist	-	-	0	0	0
StabiliTrak Electronic Stability Control System	S	S	S	S	S
<b>AUDIO SYSTEMS</b>					
AM/FM stereo with MP3-compatible CD player	S	S	S	S	S
AM/FM stereo with MP3-compatible in-dash six-disc CD changer	-	-	0	0	0
Bose <sup>®</sup> speaker system	-	-	-	0	S
DVD entertainment system: rear-seat	-	-	-	0	0
Rear-seat audio controls	-	-	-	0	S
Touch-screen navigation radio <sup>16</sup>	-	-	-	-	0
XM Radio: <sup>17</sup> includes three trial months of service	S	S	S	S	S

PICKUP MODEL	SERIES	DRIVE	TRIM LEVELS	STANDARD ENGINE	HP @ RPM	TORQUE @ RPM	STANDARD TRANSMISSIONS	OPTIONAL ENGINES	GVWR <sup>18</sup> (LBS.)	MAX. PAYLOAD <sup>19</sup> (LBS.)
<b>CREW CAB SHORT BOX</b>	1500 (1/2-ton)	2WD/4x4	Work Truck, LS, <sup>1</sup> 1LT, 2LT, LTZ	Vortec 4.8L V8 <sup>20</sup>	295 @ 5,600	305 @ 4,800	Hydra-Matic 4-speed automatic overdrive	Vortec 5.3L V8, Vortec MAX 6.0L V8	6,800 (2WD) 7,000 (4x4)	1,652 (2WD) 1,674 (4x4)
MAX Trailing Pack	1500 (1/2-ton)	2WD/4x4	1LT, 2LT, LTZ	Vortec MAX 6.0L V8	367 @ 5,500	375 @ 4,300	Hydra-Matic SD 4-speed automatic overdrive	-	7,100 (2WD) 7,300 (4x4)	1,965 (2WD) 1,921 (4x4)
<b>CREW CAB STANDARD BOX</b>	2500HD (3/4-ton)	2WD/4x4	Work Truck, 1LT, 2LT, LTZ	Vortec 6.0L V8	353 @ 5,400	373 @ 4,400	Hydra-Matic 6-speed automatic overdrive	Duramax Diesel 6.6L V8	9,200	3,458 (2WD) 3,217 (4x4)
<b>CREW CAB LONG BOX</b>	2500HD (3/4-ton)	2WD/4x4	Work Truck, 1LT, 2LT, LTZ	Vortec 6.0L V8	353 @ 5,400	373 @ 4,400	Hydra-Matic 6-speed automatic overdrive	Duramax Diesel 6.6L V8	9,200	3,301 (2WD) 3,031 (4x4)
	3500HD (1-ton)	2WD/4x4	Work Truck, 1LT, 2LT, LTZ	Vortec 6.0L V8	353 @ 5,400 <sup>21</sup> 312 @ 4,400 <sup>22</sup>	373 @ 4,400	Hydra-Matic 6-speed automatic overdrive	Duramax Diesel 6.6L V8	9,900 <sup>21</sup> 11,400 <sup>22</sup>	3,621 <sup>21</sup> /4,979 <sup>22</sup> (2WD) 3,500 <sup>21</sup> /4,706 <sup>22</sup> (4x4)

1 1500 models only. 2 Requires the available 1LT Convenience Package. 3 Mirrors are Black. 4 Requires the available 2LT Convenience Package. 5 Mirror caps are body-color. 6 Standard on 4x4 models. 7 Requires the available Safety Package. 8 Requires the available Towing Package. 9 Requires the available Vortec MAX 6.0L V8 engine and StabiliTrak Electronic Stability Control System. 10 Included with Z71 Off-Road Package and Snow Plow Prep Package. 2WD models require Z71 Off-Road Package. 11 Not available on Long Box models or on trucks equipped with Vortec 4.3L V6 or 4.8L V8 engines. Requires available 20-inch five-spoke machined-aluminum wheels. 12 Includes Z85 Handling/Trailer suspension. 13 Not available with Vortec 4.3L V6 engine or Solid Smooth Ride suspension. 14 Always use safety belts and the correct child restraint for your child's age and size. Even in vehicles equipped with the Passenger Sensing System, children are safer when properly secured in a rear seat in the appropriate infant, child or booster seat. Never place a rear-facing infant restraint in the front seat of any vehicle equipped with an active air bag. See the vehicle Owner's Manual and child safety seat instructions for more information. 15 Call 1-888-4ONSTAR (1-888-466-7827), visit onstar.com and see page 47 for system limitations and details. OnStar acts as a link to emergency services. 16 Map coverage not available in Puerto Rico, the Virgin Islands and portions of Canada. 17 Available only in the 48 contiguous United States. Required \$12.95 monthly subscription sold separately after three trial months. All fees and programming subject to change. Subscription subject to customer agreement. For more information, visit gm.xmradio.com. 18 Gross Vehicle Weight Rating (GVWR). When properly equipped; includes vehicle, passengers, cargo and equipment. 19 Maximum payload capacity includes weight of driver, passengers, optional equipment and cargo. Cargo and load capacity limited by weight and distribution. 20 Standard engine depends on trim level. 21 Single-Rear Wheel. 22 Dual-Rear Wheel.

# SILVERADO & SILVERADO HD BALL-HITCH TRAILERING

## SILVERADO 1500 BALL-HITCH TRAILERING

Weight-carrying hitch limit: 5,000-lb. trailer with 600-lb. tongue weight. Z85 Handling/Trailer Suspension or Z71 Off-Road Package and a weight-distributing hitch with sway control required over 5,000-lb. trailer weight. Please read the Trailering Basics on page 43 before towing a trailer with any Chevy Truck.

VORTEC 4.3L V6	BOX LENGTH (FT.)	MAX. TRAILER WEIGHT <sup>1</sup> (LBS.)	REQUIRED AXLE RATIO	GCWR <sup>2</sup> (LBS.)
1500 2WD Regular Cab	6.5/8	4,800/4,700 5,300/5,200	3.23 3.73	9,500 10,000
1500 2WD Extended Cab	5.8/6.5 5.8/6.5	4,400/4,300 4,900/4,800	3.23 3.73	9,500 10,000
1500 4x4 Regular Cab	6.5/8	5,100/4,900	3.73	10,000
<b>VORTEC 4.8L V8</b>				
1500 2WD Regular Cab	6.5/8 6.5/8	5,200/5,100 7,200/7,100	3.23 3.73	10,000 12,000
1500 2WD Extended Cab	5.8/6.5 5.8/6.5	4,800/4,700 6,800/6,700	3.23 3.73	10,000 12,000
1500 2WD Crew Cab	5.8 5.8	4,600 6,600	3.23 3.73	10,000 12,000
1500 4x4 Regular Cab	6.5/8 6.5/8	5,900/5,900 7,900/7,900	3.42 4.10	11,000 13,000
1500 4x4 Extended Cab	5.8/6.5 5.8/6.5	5,500/5,500 7,500/7,500	3.42 4.10	11,000 13,000
1500 4x4 Crew Cab	5.8 5.8	5,400 7,400	3.42 4.10	11,000 13,000
<b>VORTEC 5.3L V8</b>				
1500 2WD Regular Cab	6.5/8 6.5/8	7,200/7,000 8,200/8,000	3.42 3.73	12,000 13,000
1500 2WD Extended Cab	5.8 5.8 6.5/8 6.5/8	6,800 7,800 6,700/6,500 7,700/7,500	3.42 3.73 3.42 3.73	12,000 13,000 12,000 13,000
1500 2WD Crew Cab	5.8 5.8	6,600 7,600	3.42 3.73	12,000 13,000
1500 4x4 Regular Cab	6.5/8 6.5/8	7,900/7,900 8,900/8,900	3.73 4.10	13,000 14,000
1500 4x4 Extended Cab	5.8 5.8 6.5/8 6.5/8	7,500 8,500 7,500/7,300 8,500/8,300	3.73 4.10 3.73 4.10	13,000 14,000 13,000 14,000
1500 4x4 Crew Cab	5.8 5.8	7,500 8,500	3.73 4.10	13,000 14,000

VORTEC MAX 6.0L V8	BOX LENGTH (FT.)	MAX. TRAILER WEIGHT <sup>1</sup> (LBS.)	REQUIRED AXLE RATIO	GCWR <sup>2</sup> (LBS.)
1500 2WD Extended Cab	5.8	8,800	3.73	14,000
1500 4x4 Extended Cab	5.8	8,500	3.73	14,000
1500 2WD Extended Cab	6.5	8,800	3.73	14,000
1500 2WD Extended Cab – MAX Trailering Pack	6.5	10,200	3.73	15,500
1500 4x4 Extended Cab	6.5	8,500	3.73	14,000
1500 4x4 Extended Cab – MAX Trailering Pack	6.5	10,500	4.10	16,000
1500 2WD Crew Cab	5.8	8,700	3.73	14,000
1500 2WD Crew Cab – MAX Trailering Pack	5.8	10,200	3.73	15,500
1500 4x4 Crew Cab	5.8	8,400	3.73	14,000
1500 4x4 Crew Cab – MAX Trailering Pack	5.8	10,500	4.10	16,000

## SILVERADO 2500HD AND 3500HD BALL-HITCH TRAILERING

Weight-carrying hitch limit: 7,500-lb. trailer with 1,000-lb. tongue weight. Weight-distributing hitch with sway control required over 7,500-lb. trailer weight. Please read the Trailering Basics on page 43 before towing a trailer with any Chevy Truck.

VORTEC 6.0L V8	BOX LENGTH (FT.)	MAX. TRAILER WEIGHT <sup>1</sup> (LBS.)	REQUIRED AXLE RATIO	GCWR <sup>2</sup> (LBS.)
2500HD Regular Cab 2WD	8	10,400 12,900	3.73 4.10	16,000 18,500
2500HD Regular Cab 4x4	8	10,200 12,700	3.73 4.10	16,000 18,500
2500HD Extended Cab 2WD	6.5/8	10,200/10,000 12,700/12,500	3.73 4.10	16,000 18,500
2500HD Extended Cab 4x4	6.5/8	9,900/9,700 12,400/12,200	3.73 4.10	16,000 18,500
2500HD Crew Cab 2WD	6.5/8	10,000/9,900 12,500/12,400	3.73 4.10	16,000 18,500
2500HD Crew Cab 4x4	6.5/8	9,800/9,600 12,300/12,100	3.73 4.10	16,000 18,500
3500HD SRW Regular Cab 2WD	8	10,100 12,600	3.73 4.10	16,000 18,500
3500HD SRW Regular Cab 4x4	8	9,900 12,400	3.73 4.10	16,000 18,500
3500HD SRW Extended Cab 2WD	8	9,700 12,200	3.73 4.10	16,000 18,500
3500HD SRW Extended Cab 4x4	8	9,500 12,000	3.73 4.10	16,000 18,500
3500HD SRW Crew Cab 2WD	8	9,600 12,100	3.73 4.10	16,000 18,500

VORTEC 6.0L V8 (CONTINUED)	BOX LENGTH (FT.)	MAX. TRAILER WEIGHT <sup>1</sup> (LBS.)	REQUIRED AXLE RATIO	GCWR <sup>2</sup> (LBS.)
3500HD SRW Crew Cab 4x4	8	9,300 11,800	3.73 4.10	16,000 18,500
3500HD DRW Regular Cab 4x4	8	9,700 12,200	3.73 4.10	16,000 18,500
3500HD DRW Extended Cab 2WD	8	9,500 12,000	3.73 4.10	16,000 18,500
3500HD DRW Extended Cab 4x4	8	9,200 11,700	3.73 4.10	16,000 18,500
3500HD DRW Crew Cab 2WD	8	9,300 11,800	3.73 4.10	16,000 18,500
3500HD DRW Crew Cab 4x4	8	9,100 11,600	3.73 4.10	16,000 18,500
<b>DURAMAX DIESEL 6.6L V8 TURBO</b>	BOX LENGTH (FT.)	MAX. TRAILER WEIGHT <sup>1</sup> (LBS.)	REQUIRED AXLE RATIO	GCWR <sup>2</sup> (LBS.)
2500HD Regular Cab 2WD	8	13,000	3.73	22,000
2500HD Regular Cab 4x4	8	13,000	3.73	22,000
2500HD Extended Cab 2WD	6.5/8	13,000/13,000	3.73	22,000
2500HD Extended Cab 4x4	6.5/8	13,000/13,000	3.73	22,000
2500HD Crew Cab 2WD	6.5/8	13,000/13,000	3.73	22,000
2500HD Crew Cab 4x4	6.5/8	13,000/13,000	3.73	22,000
3500HD SRW Regular Cab 4x4	8	13,000	3.73	22,000
3500HD SRW Extended Cab 2WD	8	13,000	3.73	22,000
3500HD SRW Extended Cab 4x4	8	13,000	3.73	22,000
3500HD SRW Crew Cab 2WD	8	13,000	3.73	22,000
3500HD SRW Crew Cab 4x4	8	13,000	3.73	22,000
3500HD DRW Regular Cab 4x4	8	13,000	3.73	23,500
3500HD DRW Extended Cab 2WD	8	13,000	3.73	23,500
3500HD DRW Extended Cab 4x4	8	13,000	3.73	23,500
3500HD DRW Crew Cab 2WD	8	13,000	3.73	23,500
3500HD DRW Crew Cab 4x4	8	13,000	3.73	23,500

SRW – Single-Rear Wheel. DRW – Dual-Rear Wheel. <sup>1</sup> Maximum trailer weight ratings are calculated assuming a base vehicle, except for any option(s) necessary to achieve the rating, plus driver. The weight of other optional equipment, passengers and cargo will reduce the maximum trailer weight your vehicle can tow. See your Chevy dealer for additional details. <sup>2</sup> Gross Combination Weight Rating. NOTE: Trailer tongue weight should be 10 to 15 percent of total loaded trailer weight (up to 1,500 lbs. on 2500HD and 3500HD models). Trailer kingpin weight should be 15 to 25 percent of total loaded trailer weight (up to 3,000 lbs. on 2500HD and up to 3,500 lbs. on 3500HD models). <sup>3</sup> Addition of trailer tongue weight/trailer kingpin weight cannot cause vehicle weights to exceed Rear Gross Axle Weight Rating (RGAWR) or Gross Vehicle Weight Rating (GVWR). These ratings can be found on the certification label located on the driver door or doorframe.

## TRAILERING BASICS

**NOTE:** Towing a trailer involves all major vehicle systems of your Chevy Truck. Easy and safe trailering requires a properly equipped vehicle, additional trailering equipment and an appropriate trailer. It also requires loading both the vehicle and trailer properly, using safe driving techniques, meeting regional legal requirements, and following break-in and maintenance schedules. The vehicle owner is responsible for obtaining the proper equipment (hitch ball, hitch type of the proper size, type and capacity) required to safely tow both the trailer and the load that will be towed. For more information, consult your Owner's Manual or speak to a trailering expert at your Chevrolet dealership. These charts will assist in determining how to best equip your Chevy Truck for trailering. To help you understand the charts, consider these trailering factors:

**RGAWR AND GVWR:** Addition of trailer hitch weight cannot cause vehicle weights to exceed Rear Gross Axle Weight Rating (RGAWR) or Gross Vehicle Weight Rating (GVWR). These ratings can be found on the certification label located on the driver door or doorframe.

**GCWR:** The Gross Combination Weight Rating is the total allowable weight of the completely loaded vehicle and trailer.

**MAXIMUM TRAILER RATING:** This rating is determined by subtracting the tow vehicle's weight (curb weight) from the GCWR. When a base vehicle (curb) weight is used, additional passenger, equipment and cargo weight reduces this rating.

**NOTE:** The safety steps described here are by no means the only precautions to be taken when trailering. See the Owner's Manual for your Chevy Silverado for additional guidelines and trailering tips.

**TRAILERING CAUTION:** If you don't use the correct equipment and drive properly, you can lose control of your vehicle when you pull a trailer. If the trailer is too heavy, your vehicle brakes may be less effective. You and your passengers could be seriously injured. Pull a trailer only after you have taken the following steps.

**TRAILER BRAKES:** If your trailer weighs more than 2,000 lbs. loaded, then it must have its own adequate brakes. Be sure to read and follow the instructions for the trailer brake controller so that it is installed, adjusted and maintained properly. **■** Don't tap into your vehicle's brake system if the trailer's brake system will use more than 0.02 cu. in. of fluid from your vehicle's master cylinder. If it does, neither braking system will work well. **■** The trailer brake parts must be able to take 3,000 psi of pressure. If everything checks out thus far, have a qualified individual make the brake fluid tap at the master cylinder port that sends fluid to the rear brakes. Use only double-walled steel brake tubing.

**HITCHES:** It's important to have the correct hitch equipment. **■** If you'll be towing a trailer that, when loaded, will weigh more than 5,000 lbs.,\* be sure to use a frame-mounted, weight-distributing hitch and sway control of the proper size. **■** If you have to make any holes in the body of your vehicle to install a trailer hitch, be sure to seal the holes if you ever remove the hitch. If they're not sealed, dirt, water and deadly carbon monoxide from the exhaust can get into your vehicle.

**FIFTH-WHEEL TRAILERING:** Silverado pickups can be equipped with a fifth-wheel or gooseneck trailer hitch. **■** Follow the manufacturer's directions for installation, but note that the hitch must be attached to the truck frame. Do not use the pickup bed for additional support. For proper kingpin tongue load distribution and control of the trailer, the hitch must be mounted so the kingpin load is placed ahead of the rear axle centerline. **■** Fifth-wheel trailer kingpin loads are higher than conventional trailer tongue loads, so pay careful attention to the truck's payload capacity and rear axle weight ratings. **■** Your Chevy dealer can help you calculate the maximum allowable payload and GVWR required for your fifth-wheel trailering application. The weight of any additional equipment and all passengers other than the driver must be subtracted from the payload weight to determine the maximum kingpin load available.

\*Maximum trailer rating may be less depending on powertrain combinations.

## SILVERADO & SILVERADO HD FIFTH-WHEEL TRAILERING

### SILVERADO 1500 FIFTH-WHEEL TRAILERING

Fifth-wheel trailering with a Silverado 1500 requires Z85 Handling/Trailering Suspension or Z71 Off-Road Package. Please read the Trailering Basics on page 43 before towing a trailer with any Chevy Truck.

VORTEC 4.8L V8	BOX LENGTH (FT.)	MAX. TRAILER WEIGHT <sup>1</sup> (LBS.)	REQUIRED AXLE RATIO	GCWR <sup>2</sup> (LBS.)
1500 2WD Regular Cab	6.5/8	7,200/7,100	3.73	12,000
1500 2WD Extended Cab	6.5	6,700	3.73	12,000
1500 4x4 Regular Cab	6.5/8	7,300/7,800	4.10	13,000
1500 4x4 Extended Cab	6.5	7,500	4.10	13,000

### VORTEC 5.3L V8

1500 2WD Regular Cab	6.5/8	7,200/7,000	3.42	12,000
	6.5/8	8,200/8,000	3.73	13,000
1500 2WD Extended Cab	6.5/8	6,700/6,600	3.42	12,000
	6.5/8	7,700/7,600	3.73	13,000
1500 4x4 Regular Cab	6.5/8	7,300/7,800	3.73	13,000
	6.5/8	8,300/8,800	4.10	14,000
1500 4x4 Extended Cab	6.5/8	7,500/7,400	3.73	13,000
	6.5/8	8,500/8,400	4.10	14,000

### VORTEC MAX 6.0L V8

1500 2WD Extended Cab	6.5	8,700	3.73	14,000
1500 2WD Extended Cab – MAX Trailering Pack	6.5	10,100	3.73	15,500
1500 4x4 Extended Cab	6.5	8,500	3.73	14,000
1500 4x4 Extended Cab – MAX Trailering Pack	6.5	10,400	4.10	16,000

### SILVERADO 2500HD AND 3500HD FIFTH-WHEEL TRAILERING

Please read the Trailering Basics on page 43 before towing a trailer with any Chevy Truck.

VORTEC 6.0L V8	BOX LENGTH (FT.)	MAX. TRAILER WEIGHT <sup>1</sup> (LBS.)	REQUIRED AXLE RATIO	GCWR <sup>2</sup> (LBS.)
2500HD Regular Cab 2WD	8	10,400	3.73	16,000
	8	12,900	4.10	18,500
2500HD Regular Cab 4x4	8	10,200	3.73	16,000
	8	12,700	4.10	18,500
2500HD Extended Cab 2WD	6.5/8	10,200/10,000	3.73	16,000
	6.5/8	12,700/12,500	4.10	18,500
2500HD Extended Cab 4x4	6.5/8	9,900/9,700	3.73	16,000
	6.5/8	12,400/12,200	4.10	18,500
2500HD Crew Cab 2WD	6.5/8	10,000/9,900	3.73	16,000
	6.5/8	12,500/12,400	4.10	18,500
2500HD Crew Cab 4x4	6.5/8	9,800/9,600	3.73	16,000
	6.5/8	12,300/12,100	4.10	18,500
3500HD SRW Regular Cab 2WD	8	10,100	3.73	16,000
	8	12,600	4.10	18,500

### VORTEC 6.0L V8 (CONTINUED)

	BOX LENGTH (FT.)	MAX. TRAILER WEIGHT <sup>1</sup> (LBS.)	REQUIRED AXLE RATIO	GCWR <sup>2</sup> (LBS.)
3500HD SRW Regular Cab 4x4	8	9,900	3.73	16,000
	8	12,400	4.10	18,500
3500HD SRW Extended Cab 2WD	8	9,700	3.73	16,000
	8	12,200	4.10	18,500
3500HD SRW Extended Cab 4x4	8	9,500	3.73	16,000
	8	12,000	4.10	18,500
3500HD SRW Crew Cab 2WD	8	9,600	3.73	16,000
	8	12,100	4.10	18,500
3500HD SRW Crew Cab 4x4	8	9,300	3.73	16,000
	8	11,800	4.10	18,500
3500HD DRW Regular Cab 4x4	8	9,700	3.73	16,000
	8	12,200	4.10	18,500
3500HD DRW Extended Cab 2WD	8	9,500	3.73	16,000
	8	12,000	4.10	18,500
3500HD DRW Extended Cab 4x4	8	9,200	3.73	16,000
	8	11,700	4.10	18,500
3500HD DRW Crew Cab 2WD	8	9,300	3.73	16,000
	8	11,800	4.10	18,500
3500HD DRW Crew Cab 4x4	8	9,100	3.73	16,000
	8	11,600	4.10	18,500

### DURAMAX DIESEL 6.6L V8 TURBO

2500HD Regular Cab 2WD	8	15,800	3.73	22,000
2500HD Regular Cab 4x4	8	15,500	3.73	22,000
2500HD Extended Cab 2WD	6.5/8	15,400/15,000	3.73	22,000
2500HD Extended Cab 4x4	6.5/8	14,300/13,400	3.73	22,000
2500HD Crew Cab 2WD	6.5/8	15,200/14,400	3.73	22,000
2500HD Crew Cab 4x4	6.5/8	13,600/12,500	3.73	22,000
3500HD SRW Regular Cab 4x4	8	15,300	3.73	22,000
3500HD SRW Extended Cab 2WD	8	15,100	3.73	22,000
3500HD SRW Extended Cab 4x4	8	14,900	3.73	22,000
3500HD SRW Crew Cab 2WD	8	14,900	3.73	22,000
3500HD SRW Crew Cab 4x4	8	14,600	3.73	22,000
3500HD DRW Regular Cab 4x4	8	16,500	3.73	23,500
3500HD DRW Extended Cab 2WD	8	16,300	3.73	23,500
3500HD DRW Extended Cab 4x4	8	16,000	3.73	23,500
3500HD DRW Crew Cab 2WD	8	16,200	3.73	23,500
3500HD DRW Crew Cab 4x4	8	15,900	3.73	23,500

SRW – Single-Rear Wheel. DRW – Dual-Rear Wheel. <sup>1</sup> Maximum trailer weight ratings are calculated assuming a base vehicle, except for any option(s) necessary to achieve the rating, plus driver. The weight of other optional equipment, passengers and cargo will reduce the maximum trailer weight your vehicle can tow. See your Chevy dealer for additional details. <sup>2</sup> Gross Combination Weight Rating. NOTE: Trailer tongue weight should be 10 to 15 percent of total loaded trailer weight (up to 1,500 lbs. on 2500HD and 3500HD models). Trailer kingpin weight should be 15 to 25 percent of total loaded trailer weight (up to 3,000 lbs. on 2500HD and up to 3,500 lbs. on 3500HD models). ■ Addition of trailer tongue weight/trailer kingpin weight cannot cause vehicle weights to exceed Rear Gross Axle Weight Rating (RGAWR) or Gross Vehicle Weight Rating (GVWR). These ratings can be found on the certification label located on the driver door or doorframe. ■ Fifth-wheel hitch is available as a dealer-installed accessory on select models. See the Trailering Basics on page 43 for more trailering information.

## SILVERADO & SILVERADO HD DIMENSIONS

### REGULAR CAB

**A** = 79.9"  
**B** = 79.9" (1500 and HD SRW),  
 95.9" (3500HD Big Dooley)  
**C** = 73.5" to 76.4"  
 (depending on model and  
 tire size selected)  
**D** = 119.0" Standard Box (1500),  
 133.0" Long Box

**E** = 205.6" Standard Box (1500),  
 224.5" Long Box (1500),  
 224.7" Long Box (HD)  
**F** = 50.6"  
**G** = 62.5"  
**H** = 116.5"  
**I** = 78.7" Standard Box (1500),  
 97.6" Long Box

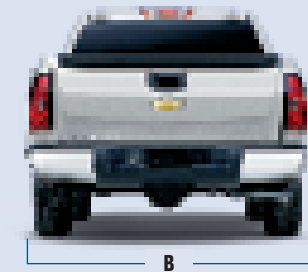
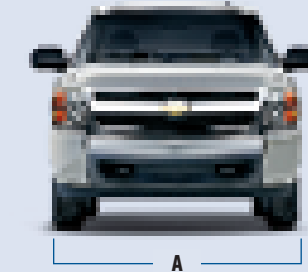

### EXTENDED CAB

**A** = 79.9"  
**B** = 79.9" (1500 and HD SRW),  
 95.9" (3500HD Big Dooley)  
**C** = 73.6" to 76.8"  
 (depending on model and  
 tire size selected)  
**D** = 133.9" Short Box (1500),  
 143.5" Standard Box,  
 157.5" Long Box

**E** = 220.3" Short Box (1500),  
 229.9" Standard Box (1500),  
 230.3" Standard Box (HD),  
 248.8" Long Box (1500),  
 249.2" Long Box (HD)  
**F** = 50.6"  
**G** = 62.5"  
**H** = 141.4"  
**I** = 69.3" Short Box (1500),  
 78.7" Standard Box,  
 97.8" Long Box



### CREW CAB

**A** = 79.9"  
**B** = 79.9" (1500 and HD SRW),  
 95.9" (3500HD Big Dooley)  
**C** = 73.7" to 77.1"  
 (depending on model and  
 tire size selected)  
**D** = 143.5" Short Box (1500),  
 153.0" Standard Box (HD),  
 160.7" Long Box (HD)

**E** = 229.9" Short Box (1500),  
 239.9" Standard Box (HD),  
 258.7" Long Box (HD)  
**F** = 50.6"  
**G** = 62.5"  
**H** = 148.9" (1500),  
 150.9" (HD)  
**I** = 69.3" Short Box (1500),  
 78.7" Standard Box (HD),  
 97.8" Long Box (HD)



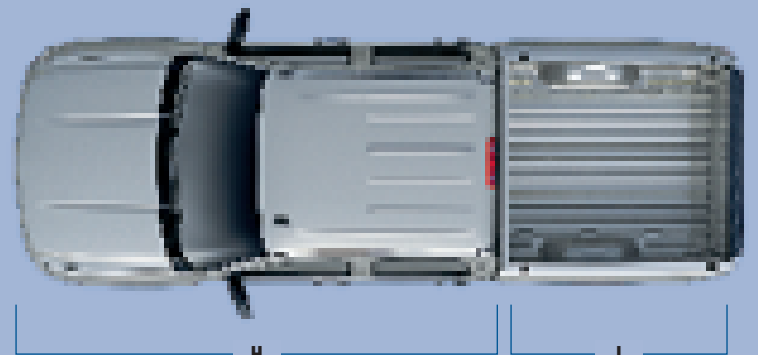
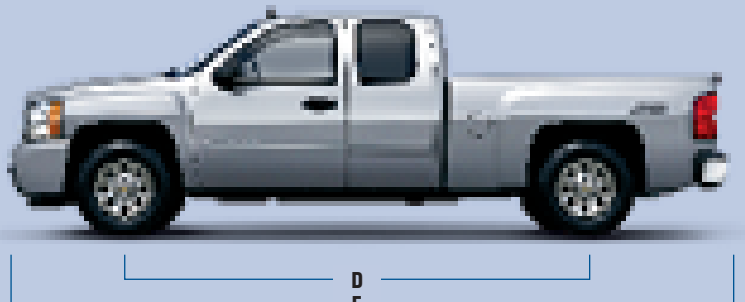
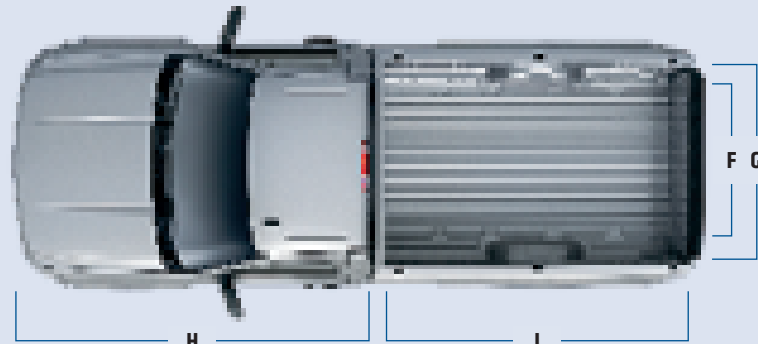
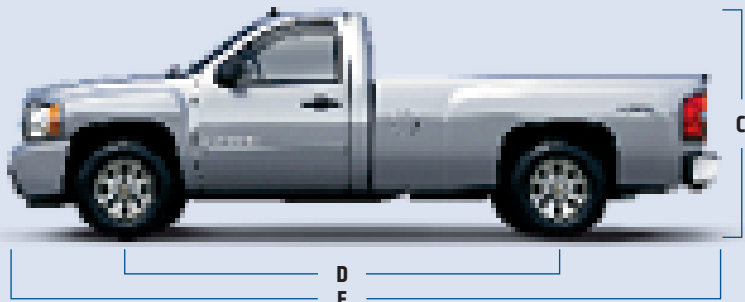

## IMPORTANT INFORMATION

**THE BEST COVERAGE IN AMERICA.** Every 2008 Chevy passenger car, light-duty truck, SUV and crossover comes with a 100,000 mile/5-year (whichever comes first) transferable Powertrain Limited Warranty. Plus, you get 100,000 miles/5 years (whichever comes first) of 24/7 Roadside Assistance, Courtesy Transportation and much more. See dealer for details.

**NEW VEHICLE LIMITED WARRANTY.** GM vehicles registered in the U.S.A. are covered for 3 years/36,000 miles (whichever comes first). The complete vehicle is covered, including tires, towing to your nearest Chevrolet dealership and cosmetic corrosion resulting from defects. Repairs will be made to correct any vehicle defect, and most warranty repairs will be made at no charge. In addition, rust-through corrosion will be covered for 6 years/100,000 miles (whichever comes first). Powertrain components will be covered for 100,000 miles/5 years (whichever comes first). See dealer for details.

**CORROSION PROTECTION.** Chevrolet vehicles are designed and built to resist corrosion. All body and sheet metal components are warranted against rust-through corrosion for 6 years/100,000 miles (whichever comes first). Application of additional rust-inhibiting materials is not required under the corrosion coverage and none is recommended. See your Chevrolet dealer for terms of this limited warranty.

**GM PROTECTION PLAN.** The GM Protection Plan is the only vehicle service contract endorsed by General Motors. The GM Protection Plan offers mechanical coverage for the parts and labor costs of repairing covered vehicle components against failure – even if it results from wear and tear (except in Kentucky). Depending on the level of coverage, additional benefits may include Roadside Assistance, alternate transportation or towing. The GM Protection Plan also offers basic maintenance coverage for specific maintenance needs. Ask your dealer about the GM Protection Plan, or visit [www.gmprotectionplan.com](http://www.gmprotectionplan.com) for coverage information and details.

**ENGINES.** Chevrolet products are equipped with engines produced by GM Powertrain or other suppliers to GM worldwide. The engines in Chevrolet products may also be used in other GM makes and models.

**ASSEMBLY.** Chevrolet vehicles and their components are assembled or produced by different operating units of General Motors, its subsidiaries or suppliers to GM worldwide. We sometimes find it necessary to produce Chevrolet vehicles with different or differently sourced components than originally scheduled. Since some options may be unavailable when your vehicle is assembled, we suggest you verify that your vehicle includes the equipment you ordered and that, if there were changes, they are acceptable to you.

**REVISIONS TO ESTIMATED FUEL ECONOMY.** Commencing with 2008 model year vehicles, EPA revised its methods for estimating vehicle fuel economy. The new test methods will likely lower MPG estimates as compared to 2007 and previous model year vehicles. These new methods are intended to better represent current driving styles, varying road and weather conditions, and certain other external factors.

**AN IMPORTANT NOTE ABOUT ALTERATIONS AND WARRANTIES.** Installations or alterations to the original GM-equipped vehicle (or chassis) are not covered by the General Motors New Vehicle Limited Warranty. The special body company, assembler, equipment installer or upfitter is solely responsible for warranties on the body or equipment and any alterations (or any effect of the alterations) to any of the parts, components, systems or assemblies installed by GM. General Motors is not responsible for the safety or quality of design features, materials or workmanship of any alterations by such suppliers.

**ONSTAR.** OnStar services require vehicle electrical system (including battery), wireless service and GPS satellite signals to be available and operating for features to function properly. OnStar acts as a link to existing emergency service providers. Subscription Service Agreement required. Call 1-888-4ONSTAR (1-888-466-7827) and visit [onstar.com](http://onstar.com) for OnStar's Terms and Conditions, Privacy Policy, and system limitations and details. Additional information can be found in the OnStar Owner's Guide.

**A NOTE ABOUT CHILD SAFETY.** Always use safety belts and the correct child restraint for your child's age and size. Even in vehicles equipped with the Passenger Sensing System, children are safer when properly secured in a rear seat in the appropriate infant, child or booster seat. Never place a rear-facing infant restraint in the front seat of any vehicle equipped with an active air bag. Air bag inflation can cause severe injury or death to anyone too close to the bag when it deploys. Be sure every occupant is properly restrained. See the vehicle Owner's Manual and child safety seat instructions for more information.

**IMPORTANT WORDS ABOUT THIS CATALOG.** We have tried to make this catalog comprehensive and factual. We reserve the right, however, to make changes at any time, without notice, in prices, colors, materials, equipment, specifications, models and availability. Specifications, dimensions, measurements, ratings and other numbers in this catalog and other printed materials provided at the dealership or affixed to vehicles are approximates based upon design and engineering drawings, prototypes and laboratory tests. Your vehicle may differ due to variations in manufacture and equipment. Since some information may have been updated since the time of printing, please check with your Chevrolet dealer for complete details. Chevrolet reserves the right to lengthen or shorten the model year for any product for any reason or to start and end model years at different times. Unless otherwise noted, all claims based on 2007 GM Large Pickup segment and latest available competitive information. Excludes other GM vehicles.

**OFF-ROADING WITH YOUR VEHICLE.** When you go off-road in your Chevy Truck, you should make sure your driving is appropriate to the vehicle and the environment. Be sure to read the "Off-Road Driving" section in your Owner's Manual. Avoid sharp turns and abrupt maneuvers. Failure to operate vehicles correctly off-road could result in loss of vehicle control or vehicle rollover. When you are off-road, make sure that all cargo is properly loaded and secured. Use boxes to organize cargo, and use nets and tie-downs to secure it. Wherever possible, use established trails, roads and areas that have been set aside for public off-road recreational driving. And obey posted regulations. Don't drive on private property without the permission of the owner; in some states, you must have it in writing. Avoid any driving practice that could harm the environment or hurt wildlife, like wheel spinning, breaking down trees, driving through streams or driving over soft ground. And never park your vehicle over dry grass or other materials that could catch fire from the heat of the vehicle's exhaust system.

GM, the GM Logo, Chevrolet, the Chevrolet Logo, and the slogans, emblems, vehicle model names, vehicle body designs and other marks appearing in this catalog are the trademarks and/or service marks of General Motors Corporation, its subsidiaries, affiliates or licensors. OnStar, Safe & Sound and Directions & Connections are registered service marks of OnStar Corp. Bose is a registered trademark of the Bose Corp. The XM name and related logos are registered trademarks of XM Satellite Radio Inc. iPod is a mobile digital device. iPod is a registered trademark of Apple, Inc. All rights reserved. ©2007 General Motors Corporation. All rights reserved. Litho in U.S.A. August 2007

## WE'VE GOT YOUR BACK

At Chevrolet, giving you a completely satisfying ownership experience is our top priority. That's why if you ever need assistance, feel free to contact us at these web sites or phone numbers.

**CHEVY.COM.** Offers shopping tools such as Build and Price, Find a Vehicle, Request Info, Email Sign-up, Compare Vehicles, Financial Tools...and much more.

**24-HOUR ROADSIDE ASSISTANCE (1-800-CHEV-USA).** Chevrolet Roadside Assistance provides you with the following services for 100,000 miles or 5 years (whichever comes first): Emergency Towing (to closest Chevy dealer from a legal roadway), Lockout Service (keys locked inside vehicle), Flat Tire Changes (spare installed), Fuel Delivery (\$5 worth of fuel delivered on the road) and Jump Starts (at home or on the road). For specific terms and conditions, please contact your Chevrolet Roadside Assistance advisor at 1-800-243-8872. Some services may incur costs.

**COURTESY TRANSPORTATION.** Ask your Chevrolet dealer for Courtesy Transportation if you leave your vehicle for extended repairs under the New Vehicle Limited Warranty or Powertrain Limited Warranty. Ask if you qualify for expense reimbursement and/or vehicle rental. Services vary by dealer.

**CHEVROLET CUSTOMER ASSISTANCE CENTER (1-800-222-1020).** Talk directly to customer relationship managers who can handle any inquiries related to vehicle operation, warranty coverages, or product or service concerns you may have. Please refer to your Owner's Manual for Customer Assistance information.

**CHEVY.COM/SAFETY.** Chevrolet is committed to keeping you and your family safe – from the start of your journey to your destination. That's why every Chevrolet is designed with a comprehensive list of safety and security features to help give you peace of mind.

**GMMOBILITY.COM (1-800-323-9935).** GM Mobility offers financial assistance for eligible adaptive equipment, innovative products like the Sit-N-Lift™ power seat, and other resources to make automotive travel easier for persons with disabilities or special transportation needs. To learn more about special GM Mobility offers, call one of our knowledgeable Assistance Center representatives or visit online.

**CHEVROLET OWNER CENTER (CHEVY.COM/MYGLINK).** Register your vehicle with the Chevrolet Owner Center, and receive benefits such as online access to your vehicle Owner's Manual, maintenance schedule reminders, service history tracking, warranty and service information, safety information, special offers and privileges, and news and events.

**MARKETING AND INCENTIVES (CHEVY.COM/SPECIALOFFERS).** Call 1-800-950-CHEV (1-800-950-2438) or visit [chevy.com/specialoffers](http://chevy.com/specialoffers) for new product, current incentive and marketing program information.

**GMCARDMEMBERSERVICES.COM.** Did you know about the family of reward credit cards that can help you get a great deal on a new GM car, light-duty truck, SUV or crossover? With a GM reward card, you accrue earnings on every credit card purchase to use toward the purchase or lease of an eligible, new GM vehicle. With three cards to choose from, you're sure to find one that suits you best.

